

Overview

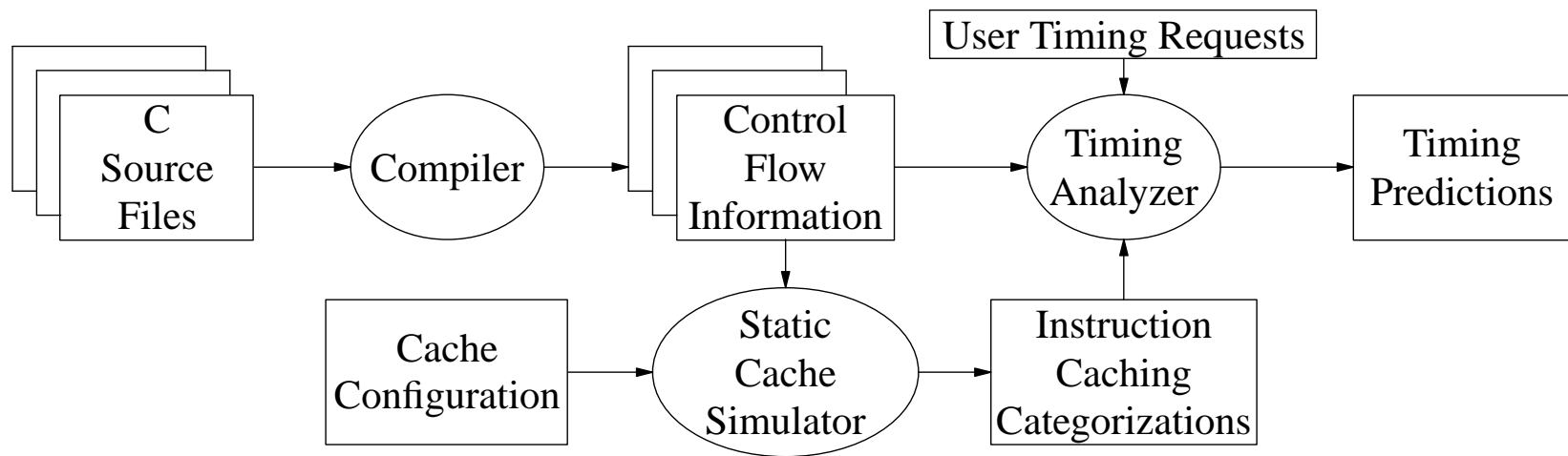

Example of a First Miss and First Hit

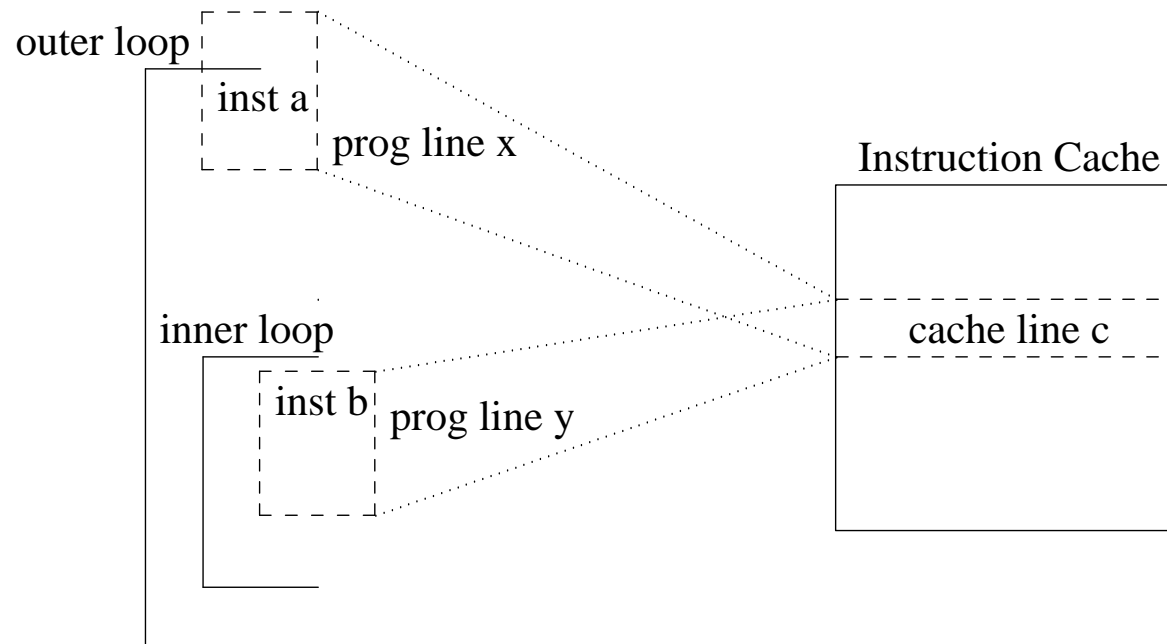

Mapping between Program and Cache Lines

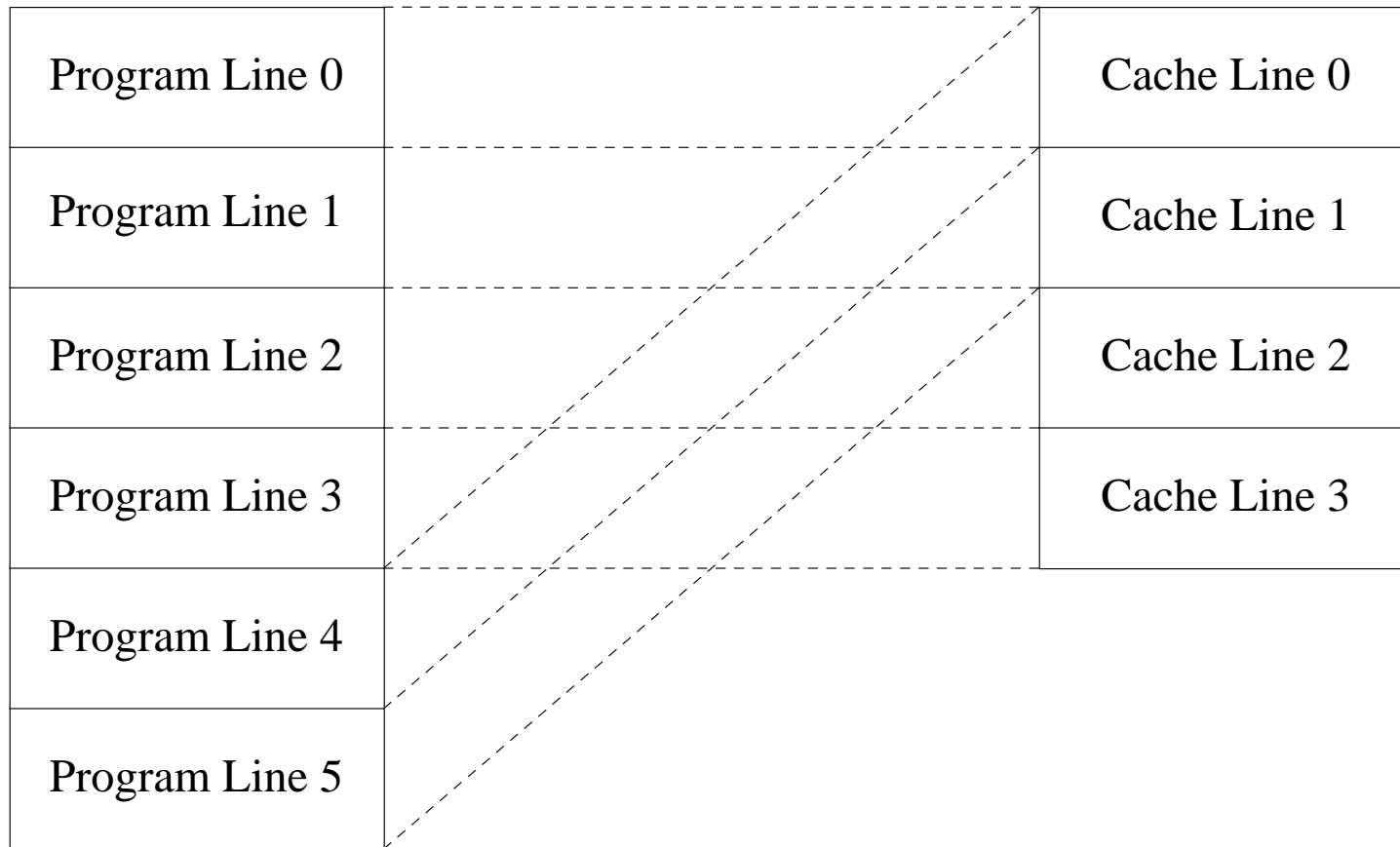

Timing Analysis Tree for Program

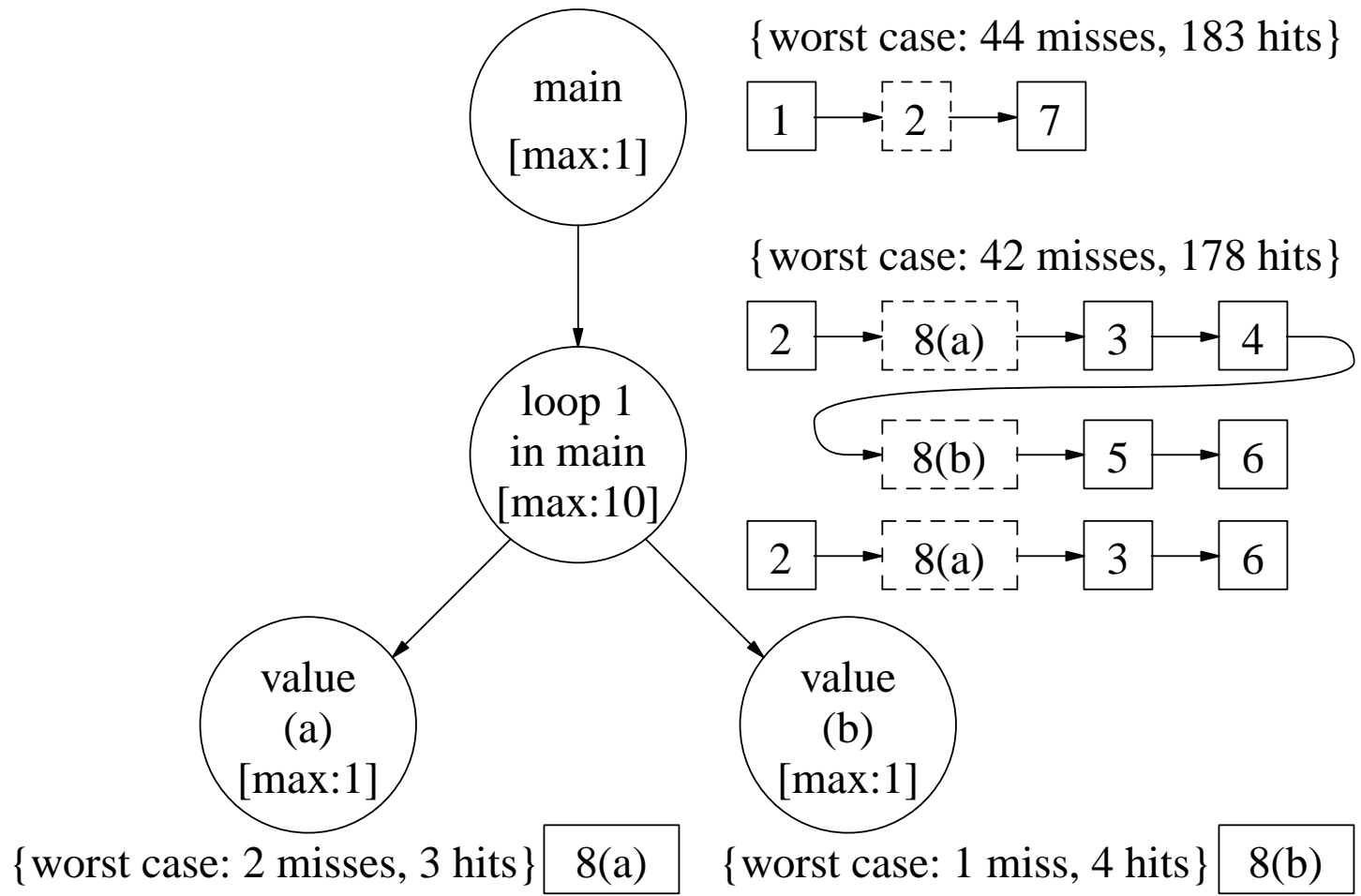

Worst Case Results for the Test Programs

Name	Size Ratio	Hit Ratio	Observed Cycles	Estim Cycles	Estim Ratio	Naive Ratio
Des	17.44	81.59%	142,079	158,678	1.12	3.88
Matcnt	6.16	85.32%	959,064	1,049,064	1.09	4.31
Matmul	6.25	99.05%	2,917,887	2,917,887	1.00	9.21
Matsum	4.94	87.09%	677,210	677,210	1.00	4.63
Sort	4.19	84.05%	7,620,684	15,198,004	1.99	8.18
Stats	15.81	88.59%	357,432	357,432	1.00	4.93