

Chapter 13: I/O Systems

- I/O Hardware
- Application I/O Interface
- Kernel I/O Subsystem
- Transforming I/O Requests to Hardware Operations
- Streams
- Performance

Objectives

- Explore the structure of an operating system's I/O subsystem
- Discuss the principles of I/O hardware and its complexity
- Provide details of the performance aspects of I/O hardware and software

I/O Hardware

- Incredible variety of I/O devices
- Common concepts
 - **Port**
 - **Bus (daisy chain** or shared direct access)
 - **Controller (host adapter)**
- I/O instructions control devices
- Devices have addresses, used by
 - Direct I/O instructions
 - **Memory-mapped I/O**

A Typical PC Bus Structure

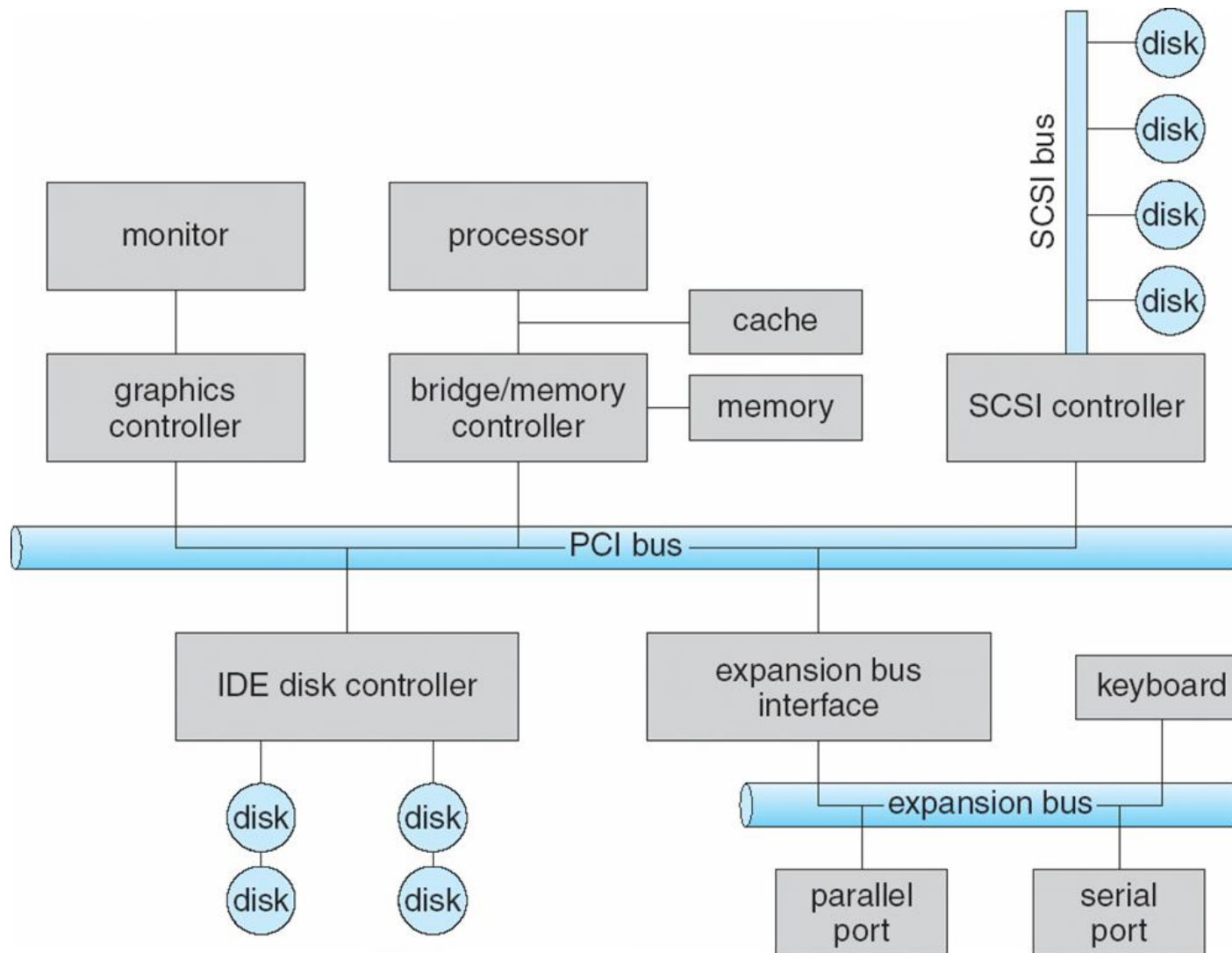

Device I/O Port Locations on PCs (partial)

I/O address range (hexadecimal)	device
000–00F	DMA controller
020–021	interrupt controller
040–043	timer
200–20F	game controller
2F8–2FF	serial port (secondary)
320–32F	hard-disk controller
378–37F	parallel port
3D0–3DF	graphics controller
3F0–3F7	diskette-drive controller
3F8–3FF	serial port (primary)

Polling

- Determines state of device
 - command-ready
 - busy
 - Error
- **Busy-wait** cycle to wait for I/O from device

Interrupts

- CPU **Interrupt-request line** triggered by I/O device
- **Interrupt handler** receives interrupts
- **Maskable** to ignore or delay some interrupts
- Interrupt vector to dispatch interrupt to correct handler
 - Based on priority
 - Some **nonmaskable**
- Interrupt mechanism also used for exceptions

Interrupt-Driven I/O Cycle

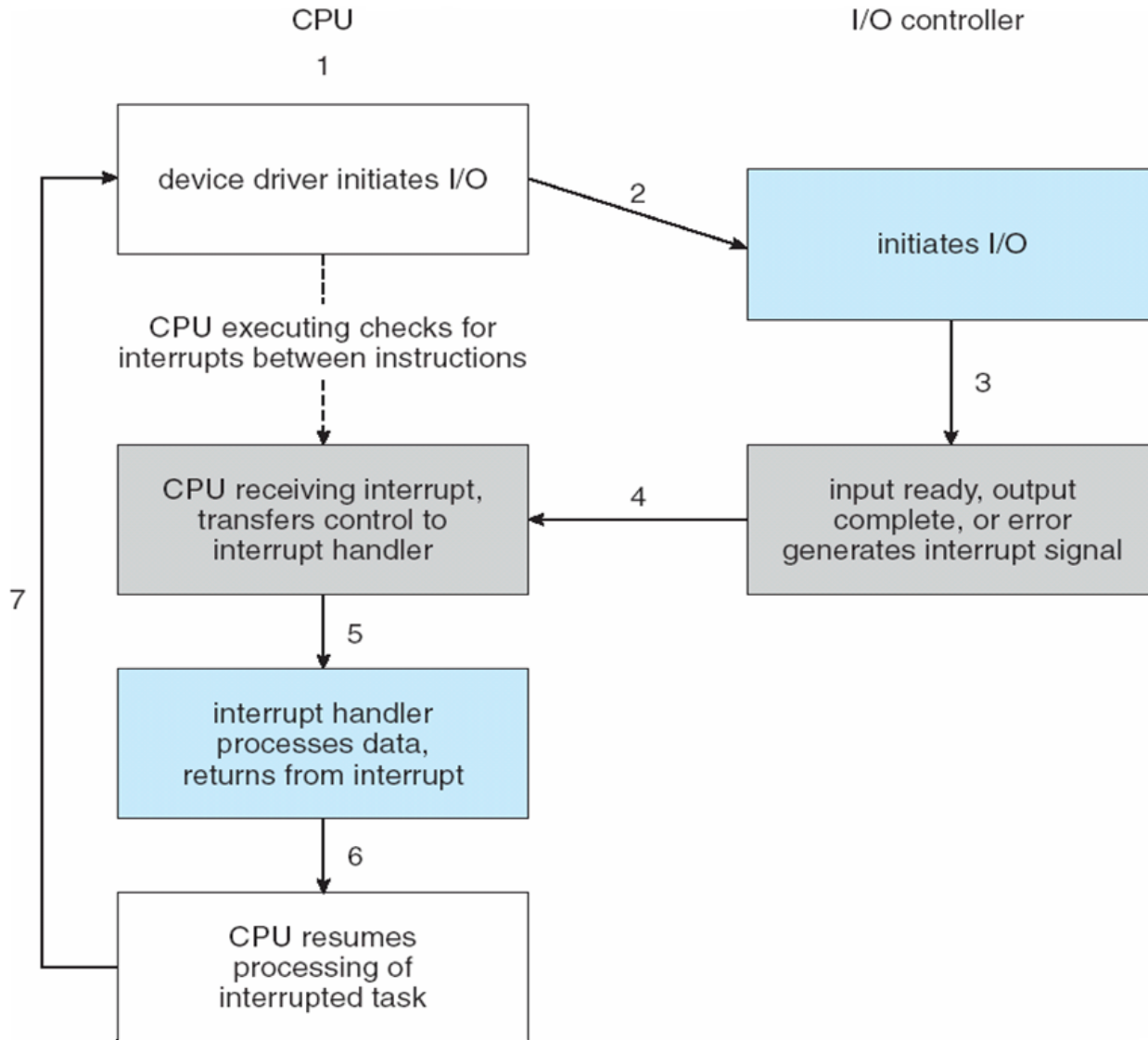

Intel Pentium Processor Event-Vector Table

vector number	description
0	divide error
1	debug exception
2	null interrupt
3	breakpoint
4	INTO-detected overflow
5	bound range exception
6	invalid opcode
7	device not available
8	double fault
9	coprocessor segment overrun (reserved)
10	invalid task state segment
11	segment not present
12	stack fault
13	general protection
14	page fault
15	(Intel reserved, do not use)
16	floating-point error
17	alignment check
18	machine check
19–31	(Intel reserved, do not use)
32–255	maskable interrupts

Direct Memory Access

- Used to avoid **programmed I/O** for large data movement
- Requires **DMA** controller
- Bypasses CPU to transfer data directly between I/O device and memory

Six Step Process to Perform DMA Transfer

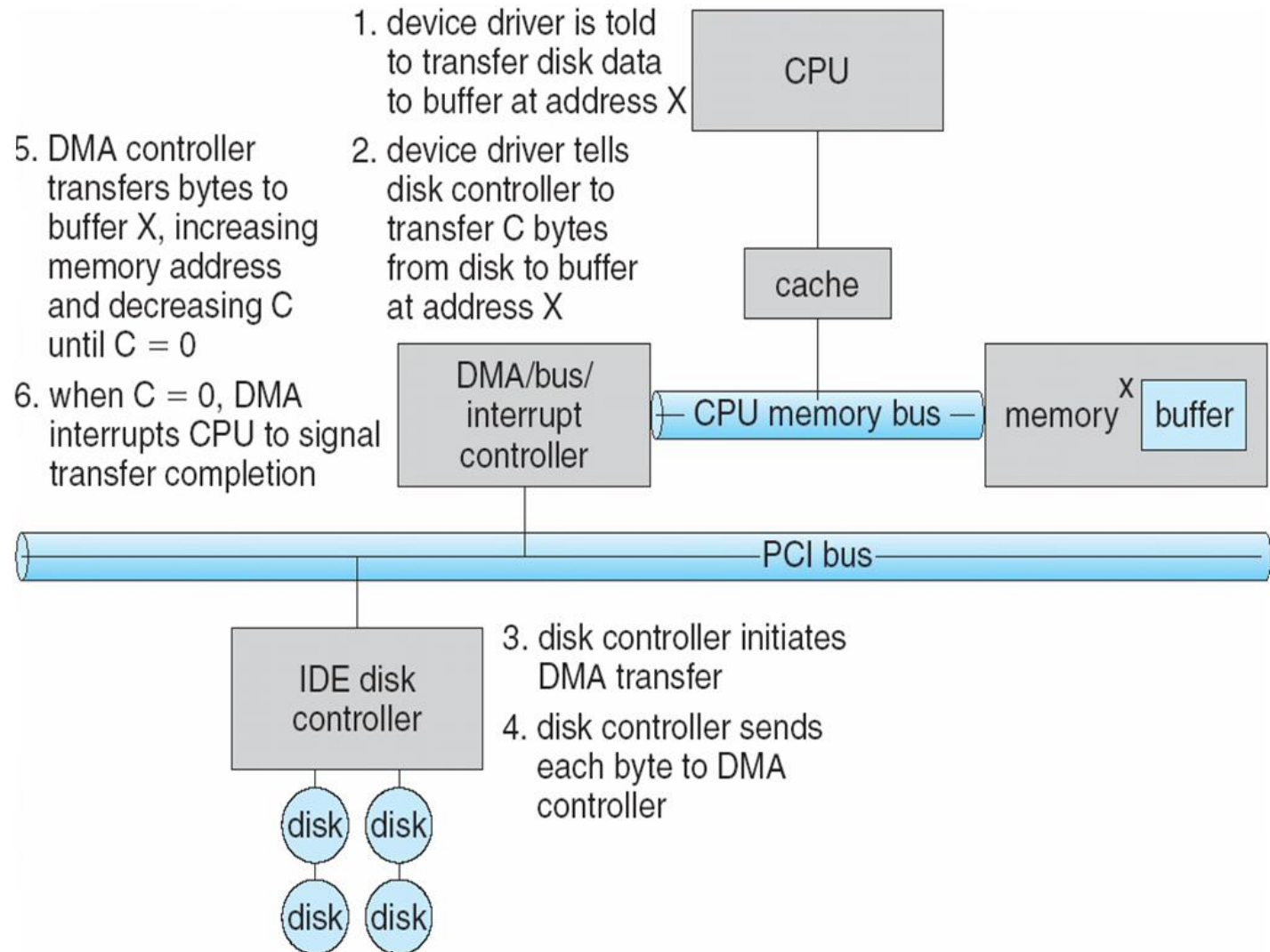

Application I/O Interface

- I/O system calls encapsulate device behaviors in generic classes
- Device-driver layer hides differences among I/O controllers from kernel
- Devices vary in many dimensions
 - **Character-stream or block**
 - **Sequential or random-access**
 - **Sharable or dedicated**
 - **Speed of operation**
 - **read-write, read only, or write only**

A Kernel I/O Structure

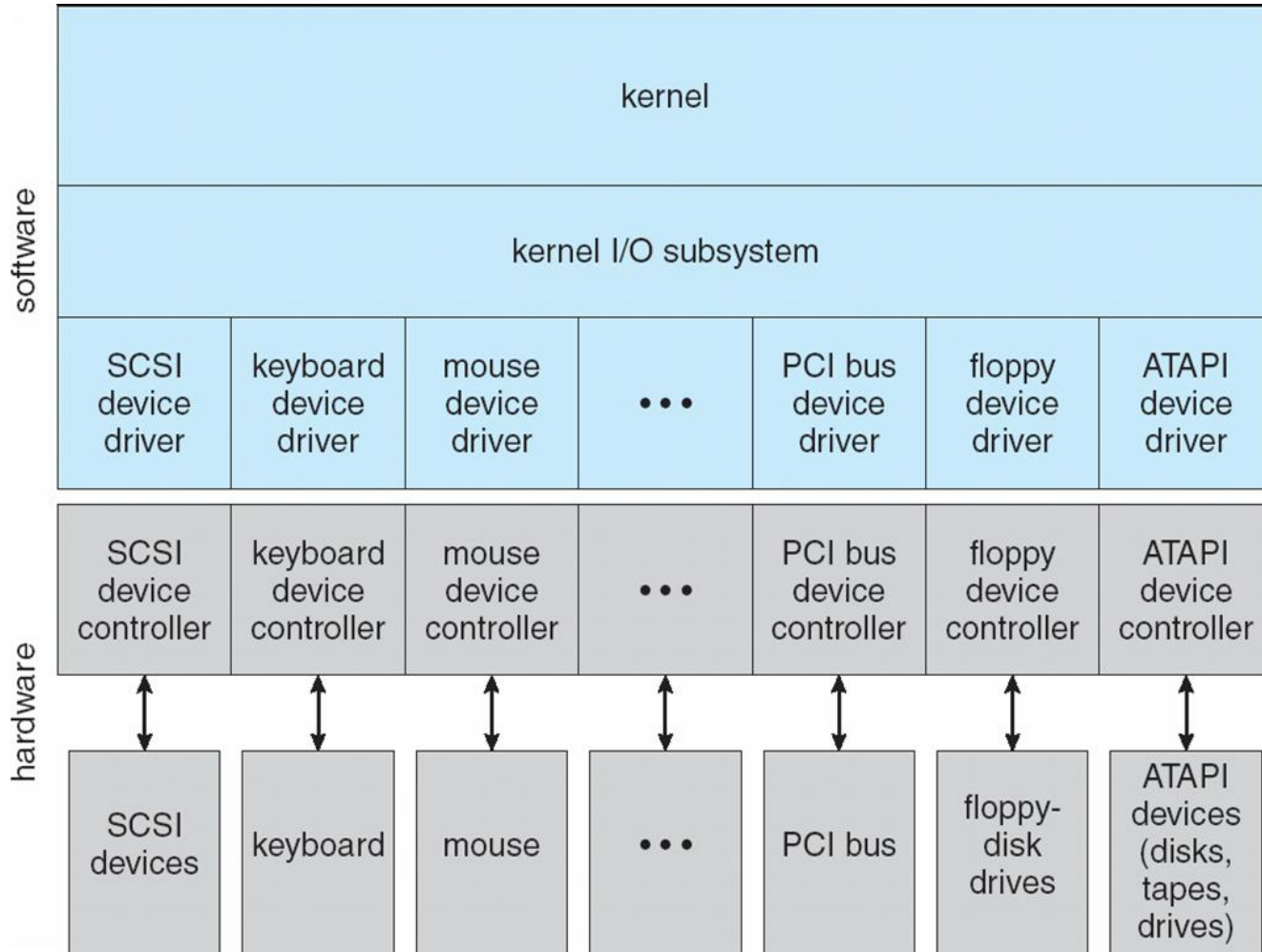

Characteristics of I/O Devices

aspect	variation	example
data-transfer mode	character block	terminal disk
access method	sequential random	modem CD-ROM
transfer schedule	synchronous asynchronous	tape keyboard
sharing	dedicated sharable	tape keyboard
device speed	latency seek time transfer rate delay between operations	
I/O direction	read only write only read–write	CD-ROM graphics controller disk

Block and Character Devices

- Block devices include disk drives
 - Commands include read, write, seek
 - Raw I/O or file-system access
 - Memory-mapped file access possible
- Character devices include keyboards, mice, serial ports
 - Commands include `get`, `put`
 - Libraries layered on top allow line editing

Network Devices

- Varying enough from block and character to have own interface
- Unix and Windows NT/9x/2000 include socket interface
 - Separates network protocol from network operation
 - Includes `select` functionality
- Approaches vary widely (pipes, FIFOs, streams, queues, mailboxes)

Clocks and Timers

- Provide current time, elapsed time, timer
- **Programmable interval timer** used for timings, periodic interrupts
- `ioctl` (on UNIX) covers odd aspects of I/O such as clocks and timers

Blocking and Nonblocking I/O

- **Blocking** - process suspended until I/O completed
 - Easy to use and understand
 - Insufficient for some needs
- **Nonblocking** - I/O call returns as much as available
 - User interface, data copy (buffered I/O)
 - Implemented via multi-threading
 - Returns quickly with count of bytes read or written
- **Asynchronous** - process runs while I/O executes
 - Difficult to use
 - I/O subsystem signals process when I/O completed

Two I/O Methods

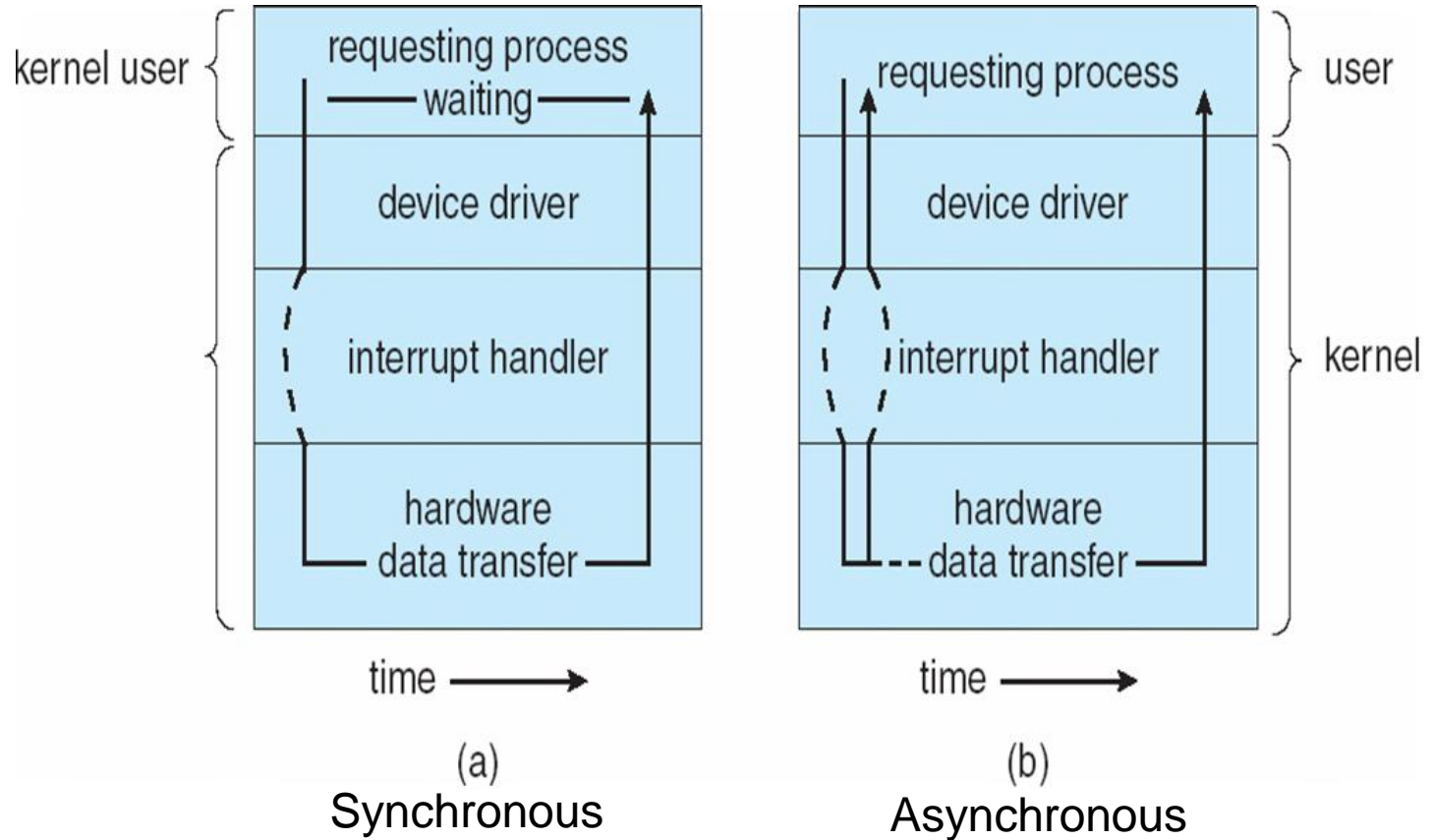

Kernel I/O Subsystem

- Scheduling
 - Some I/O request ordering via per-device queue
 - Some OSs try fairness
- Buffering - store data in memory while transferring between devices
 - To cope with device speed mismatch
 - To cope with device transfer size mismatch
 - To maintain “copy semantics”

Device-status Table

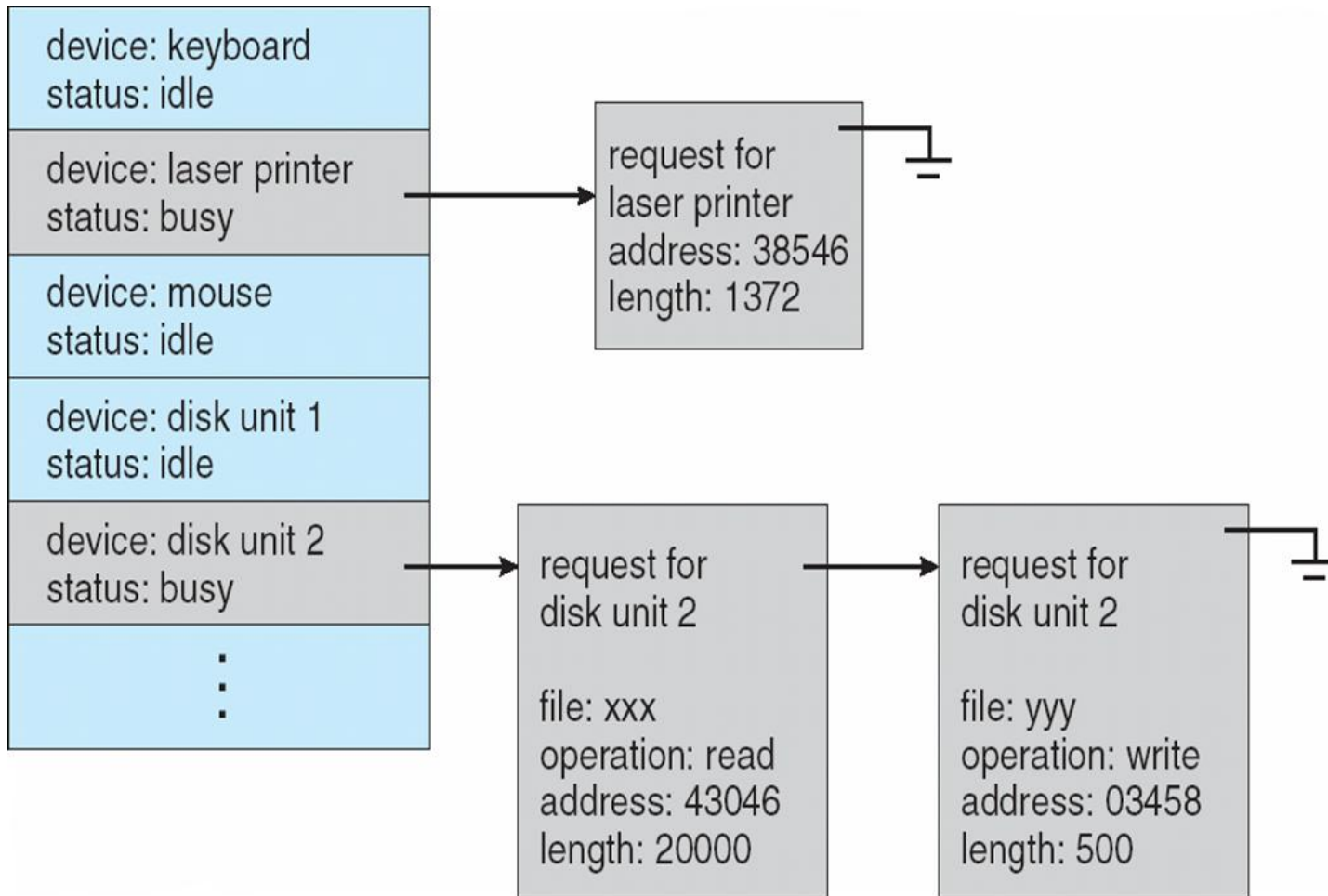

Sun Enterprise 6000 Device-Transfer Rates

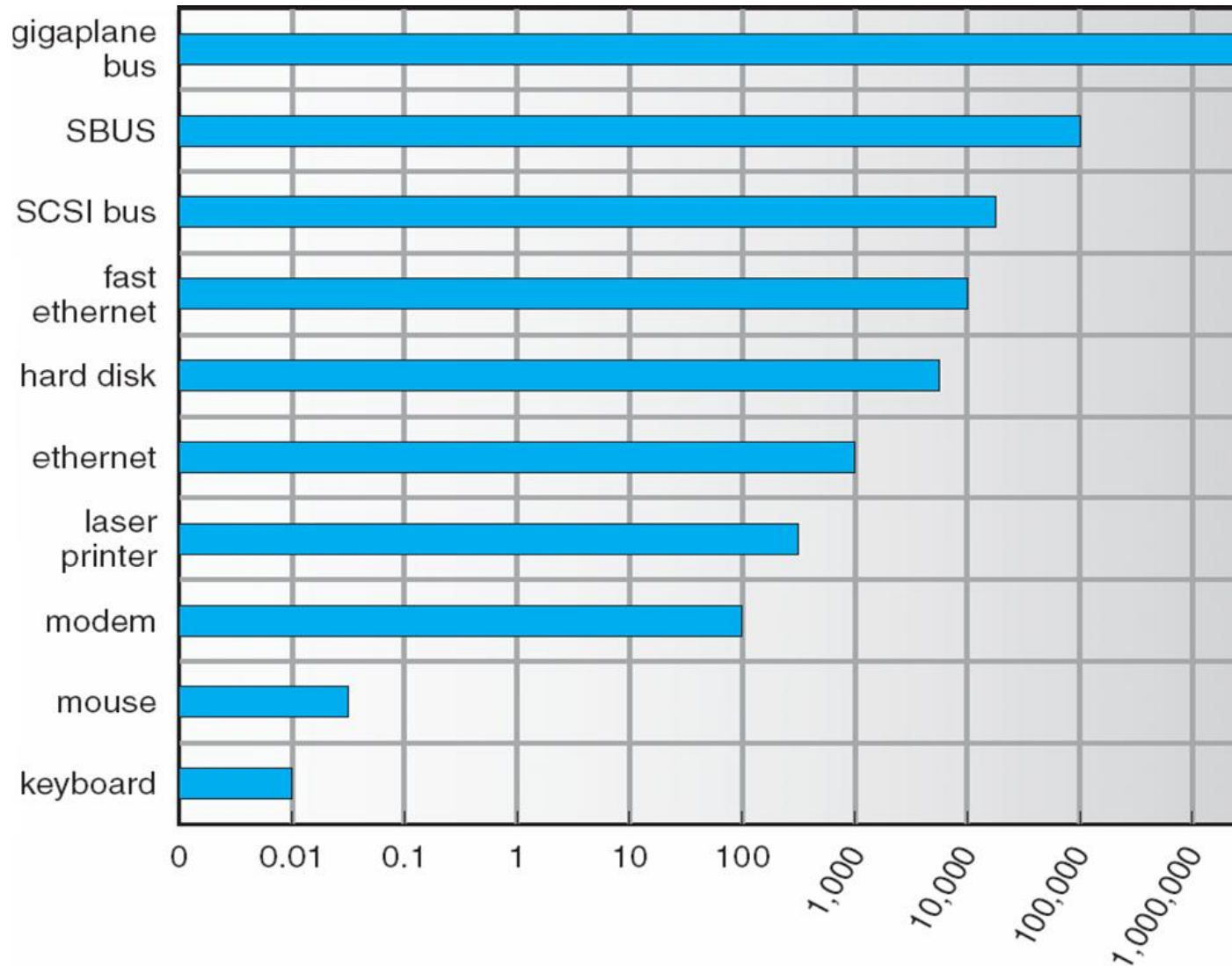

Kernel I/O Subsystem

- **Caching** - fast memory holding copy of data
 - Always just a copy
 - Key to performance
- **Spooling** - hold output for a device
 - If device can serve only one request at a time
 - i.e., Printing
- **Device reservation** - provides exclusive access to a device
 - System calls for allocation and deallocation
 - Watch out for deadlock

Error Handling

- OS can recover from disk read, device unavailable, transient write failures
- Most return an error number or code when I/O request fails
- System error logs hold problem reports

I/O Protection

- User process may accidentally or purposefully attempt to disrupt normal operation via illegal I/O instructions
 - All I/O instructions defined to be privileged
 - I/O must be performed via system calls
 - ▶ Memory-mapped and I/O port memory locations must be protected too

Use of a System Call to Perform I/O

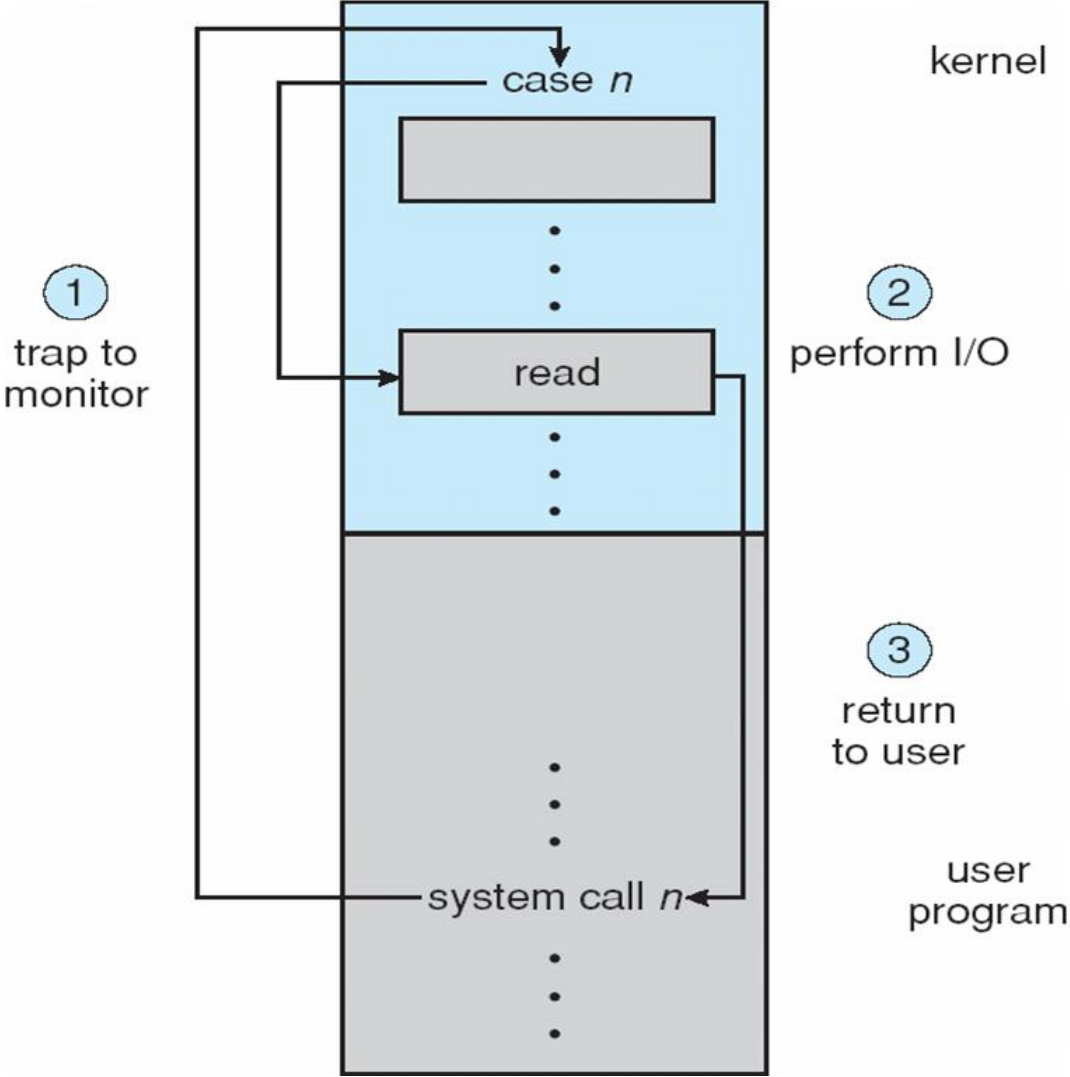

Kernel Data Structures

- Kernel keeps state info for I/O components, including open file tables, network connections, character device state
- Many, many complex data structures to track buffers, memory allocation, “dirty” blocks
- Some use object-oriented methods and message passing to implement I/O

UNIX I/O Kernel Structure

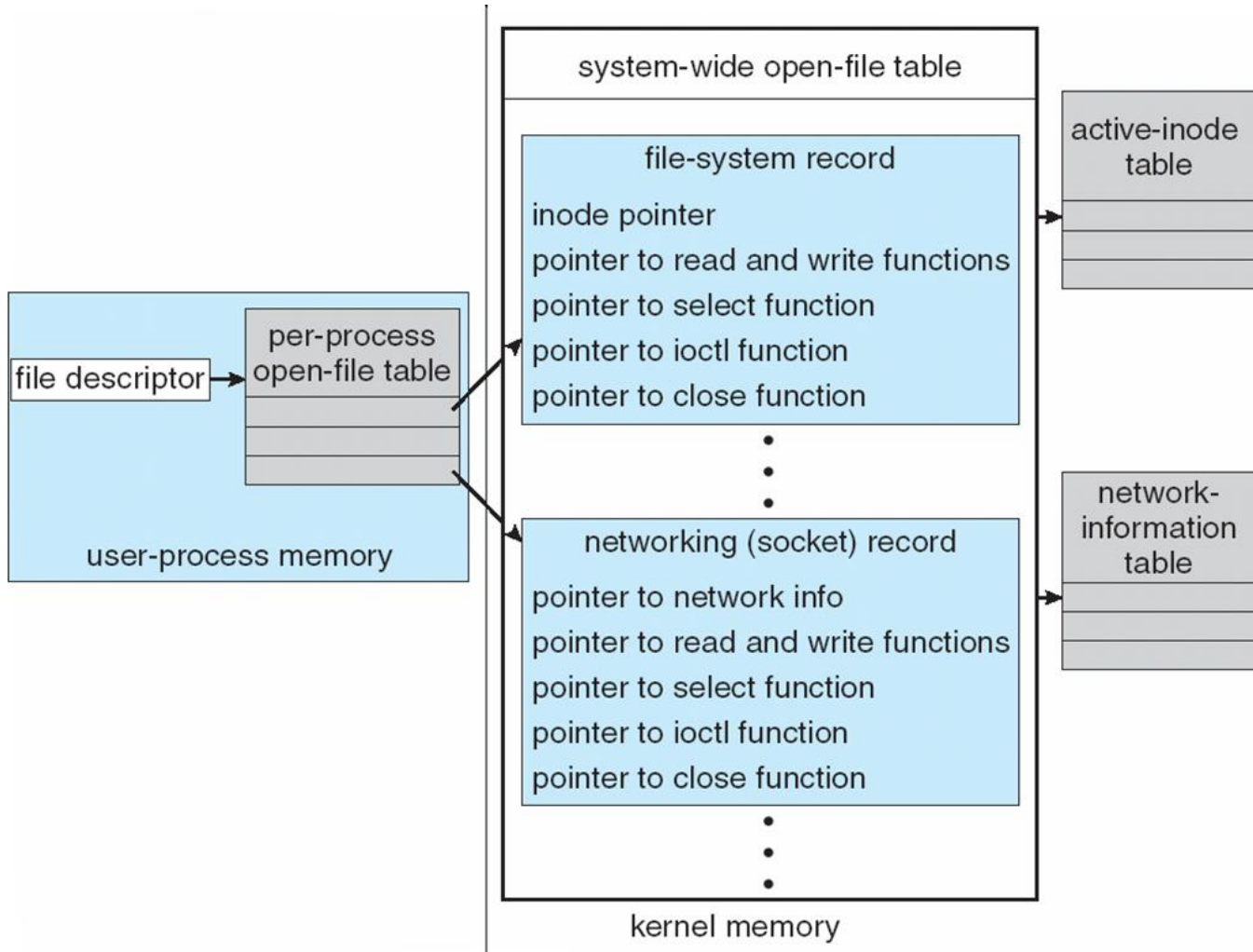

I/O Requests to Hardware Operations

- Consider reading a file from disk for a process:
 - Determine device holding file
 - Translate name to device representation
 - Physically read data from disk into buffer
 - Make data available to requesting process
 - Return control to process

Life Cycle of An I/O Request

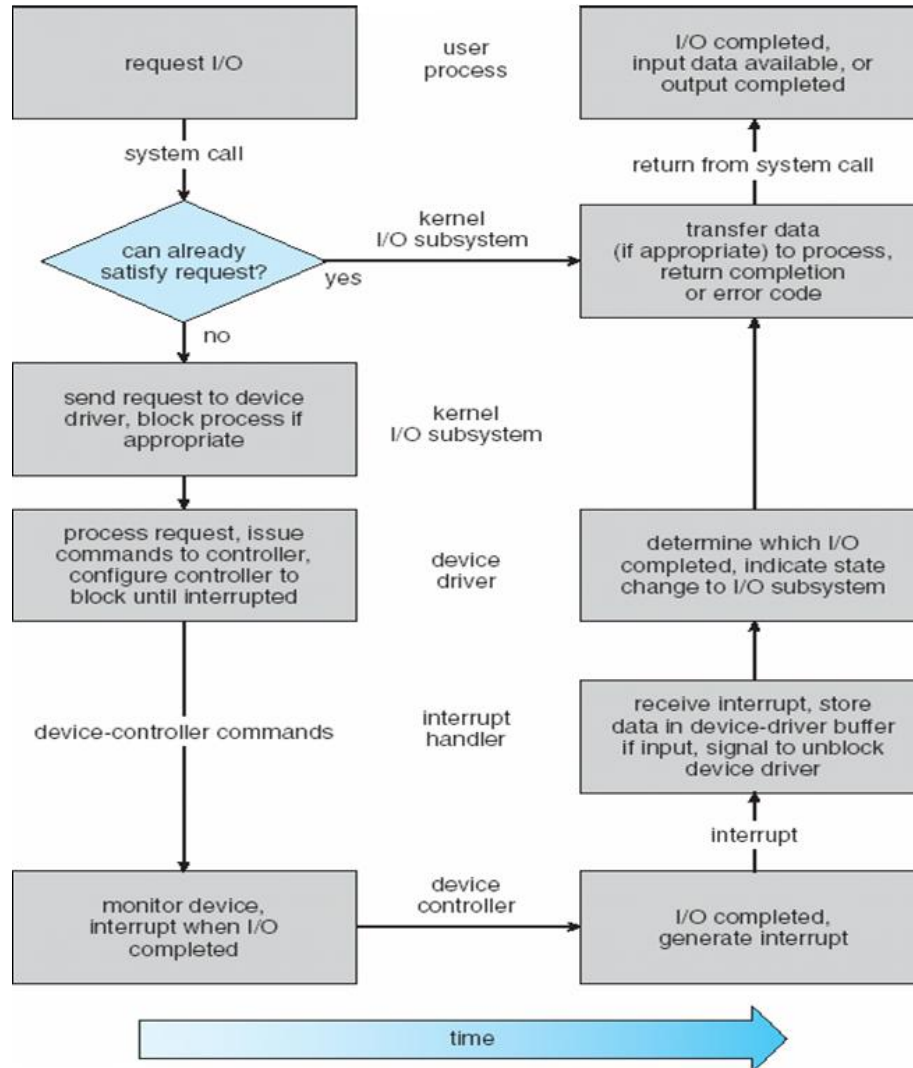

STREAMS

- **STREAM** – a full-duplex communication channel between a user-level process and a device in Unix System V and beyond
- A STREAM consists of:
 - STREAM head interfaces with the user process
 - driver end interfaces with the device
 - zero or more STREAM modules between them.
- Each module contains a **read queue** and a **write queue**
- Message passing is used to communicate between queues

The STREAMS Structure

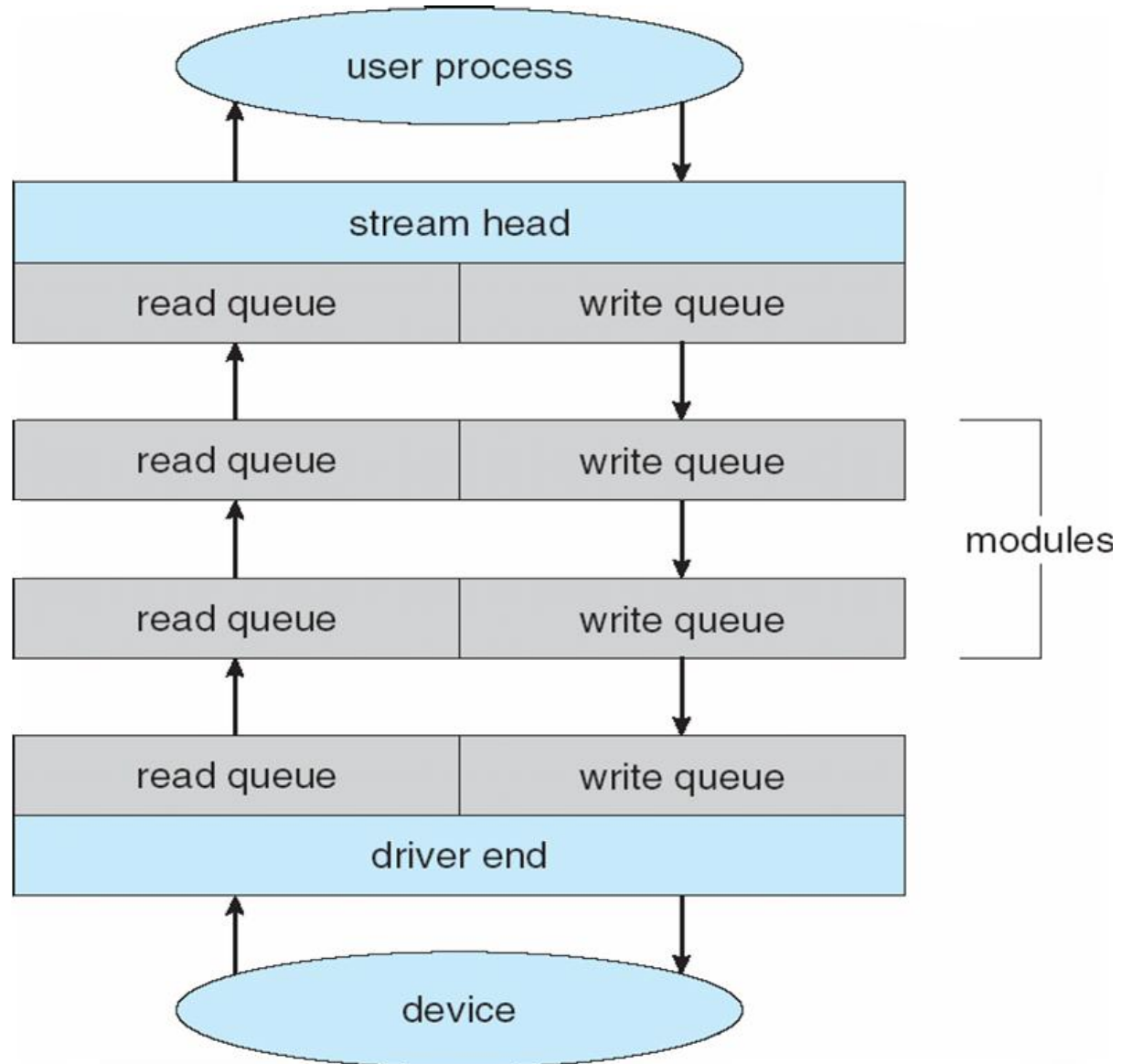

Performance

- I/O a major factor in system performance:
 - Demands CPU to execute device driver, kernel I/O code
 - Context switches due to interrupts
 - Data copying
 - Network traffic especially stressful

Improving Performance

- Reduce number of context switches
- Reduce data copying
- Reduce interrupts by using large transfers, smart controllers, polling
- Use DMA
- Balance CPU, memory, bus, and I/O performance for highest throughput

Device-Functionality Progression

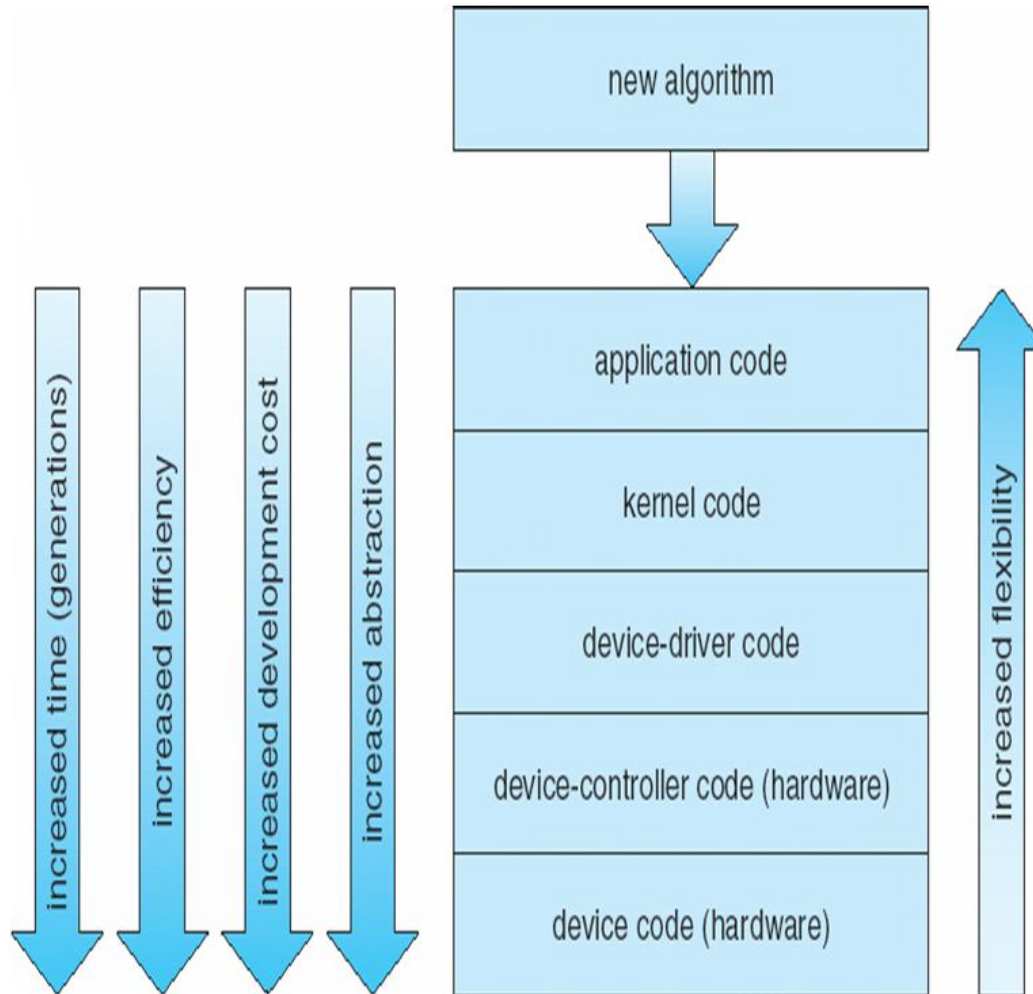

End of Chapter 13